

1. Absolute Type-Parallel output (Hollow Shaft Blind Hole)

1.1 Introduction:

KJ38 is a small economic universal design, compact, sturdy, high safety, and commonly used in industrial automations.

1.2 Feature:

- Encoder external diameter Ø38mm、 thickness 38mm、 diameter of shaft up to Ø5mm、 Ø6mm、 Ø8mm;
- Adopt non-contact photoelectric principle;
- Multiple electrical interfaces available;
- Resolution per turn up to 11Bits(2048)

1.3 Application:

Textile, packaging, motor, elevator, CNC and other automation control fields.

1.4 Connection:

- Radial cable (STD length 1000mm)
- Radial cable with plug (STD length 1000mm)
- Axial cable (STD length 1000mm)
- Axial cable with plug (STD length 1000mm)

1.5 Protection:

IP50 & IP65

1.6 Weight:

About 140g



KJ38-T

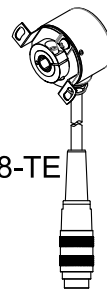

KJ38-TE

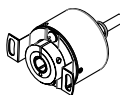

KJ38-Q

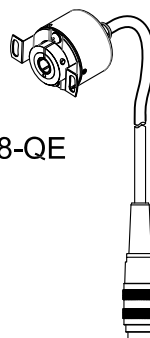

KJ38-QE

2. Model Selection Guide

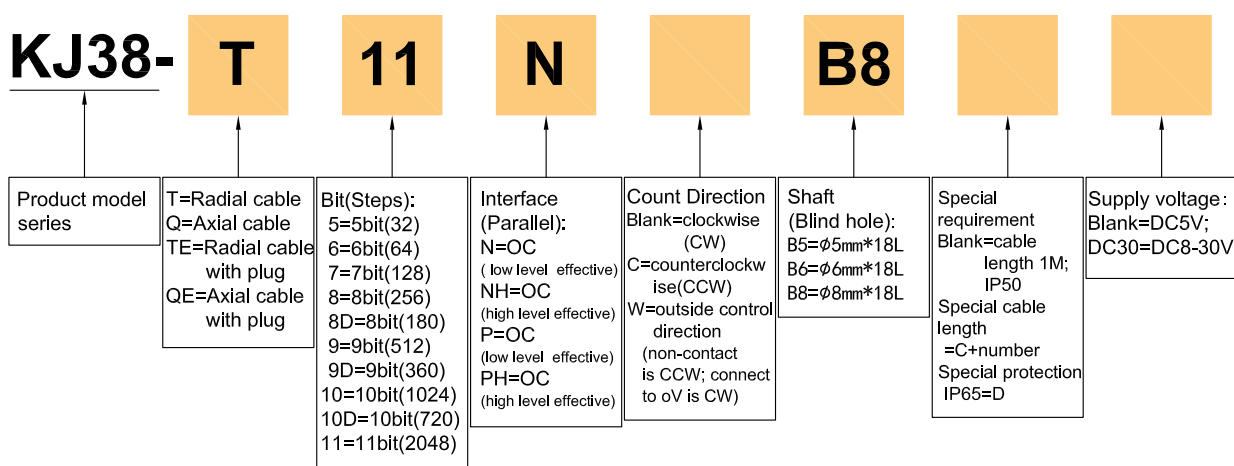

3. Resolution Output Table

	bit										
	11	10	9	8	7	6	5	4	3	2	1
0	0	0	0	0	0	0	0	0	0	0	0
1	0	0	0	0	0	0	0	0	0	0	1
2	0	0	0	0	0	0	0	0	0	1	1
31	0	0	0	0	0	0	1	0	0	0	0
32	0	0	0	0	0	1	1	0	0	0	0
37	0	0	0	0	0	1	1	0	1	1	1
38	0	0	0	0	0	1	1	0	1	0	1
63	0	0	0	0	0	1	0	0	0	0	0
64	0	0	0	0	1	1	0	0	0	0	0
75	0	0	0	0	1	1	0	1	1	1	0
76	0	0	0	0	1	1	0	1	0	1	0
127	0	0	0	0	1	0	0	0	0	0	0
128	0	0	0	1	1	0	0	0	0	0	0
151	0	0	0	1	1	0	1	1	1	0	0
152	0	0	0	1	1	0	1	0	1	0	0
217	0	0	0	1	0	1	1	0	1	0	1
218	0	0	0	1	0	1	1	0	1	1	1
255	0	0	0	1	0	0	0	0	0	0	0
256	0	0	1	1	0	0	0	0	0	0	0
435	0	0	1	0	1	1	0	1	0	1	0
436	0	0	1	0	1	1	0	1	1	1	0
511	0	0	1	0	0	0	0	0	0	0	0
512	0	1	1	0	0	0	0	0	0	0	0
871	0	1	0	1	1	0	1	0	1	0	0
872	0	1	0	1	1	0	1	1	1	0	0
1023	0	1	0	0	0	0	0	0	0	0	0
1024	1	1	0	0	0	0	0	0	0	0	0
2046	1	0	0	0	0	0	0	0	0	0	1
2047	1	0	0	0	0	0	0	0	0	0	0

4. Output Mode

Interface(Parallel)	Output circuit	Output wave form
<p>OC (NPN)</p>		<p>Position: 0 1 2 3 4 5 6 7 8 9 10 11 12 13 14 15 16 17 18 19 20 21.....2047</p> <p>View from shaft end,rotate direction is clockwise(CW)</p>
<p>OC (PNP)</p>		<p>Position: 0 1 2 3 4 5 6 7 8 9 10 11 12 13 14 15 16 17 18 19 20 21.....2047</p> <p>View from shaft end,rotate direction is clockwise(CW)</p>

5. Electrical Characteristics

Parameter / Item	Interface (Parallel)	OC(NPN)	OC(PNP)
Supply voltage		DC5V±5%; DC8V-30V±5%	
Allowable ripple		≤3%rms	
Consumption current		100mA Max	
Output code		gray code	
Precision		[360/(resolutionx4)]°	
Top response frequency		100kHz Max	
Output capacity	Output current	Input	≤30mA
		Output	—
	Output voltage	“H”	—
		“L”	≤0.4V
	Load voltage	≤DC30V	
Rise & Fall time		Less than 2us (Load resistance 1KΩ、cable length: 2m)	
Output level		Low level available	High level available
Insulation strength		AC500V 60s	
Insulation resistance		10MΩ	
GND		not connect to encoder	

6. Mechanical Characteristics

Shaft	Ø5mm、Ø6mm、Ø8mm(stainless steel, Blind hole,Depth 18mm)
Starting torque	Less than $9,8 \times 10^{-3}$ N·m
Inertia moment	Less than $6,5 \times 10^{-6}$ kg·m ²
Shaft load	Radial 30N; Axial 20N
Slew speed	≤3000 rpm; IP65≤2000 rpm
Bearing Life	$1,5 \times 10^9$ revs at rated load(10000hrs at 2500RPM)
Shell	Die cast aluminum
Weight	About 140g (with package)

7. Environmental Specifications

Environmental temperature	Operating: -20~+85°C(repeatable winding cable; -10°C); storage: -25~+90°C
Environmental humidity	Operating and storage: 35~85%RH(noncondensing)
Vibration(endure)	Amplitude 0.75mm, 10~50Hz, 1h for X,Y,Z direction individually
Shock(endure)	49m/s ² , three times for X,Y,Z direction individually
Protection	IP50; IP65

8. Wiring table

Socket Pin No. & Color	Resolution2048	Resolution1024 (720)	Resolution512 (360)	Resolution256 (180)	Resolution 128	Resolution 64	Resolution 32
14=P=gray/black	bit1(2 ⁰)	not connect	←	←	←	←	←
13=O=blue/black	bit2(2 ¹)	bit1(2 ⁰)	not connect	←	←	←	←
12=N=yellow/black	bit3(2 ²)	bit2(2 ¹)	bit1(2 ⁰)	not connect	←	←	←
11=M=green/black	bit4(2 ³)	bit3(2 ²)	bit2(2 ¹)	bit1(2 ⁰)	not connect	←	←
10=L=white/black	bit5(2 ⁴)	bit4(2 ³)	bit3(2 ²)	bit2(2 ¹)	bit1(2 ⁰)	not connect	←
9=K=pink	bit6(2 ⁵)	bit5(2 ⁴)	bit4(2 ³)	bit3(2 ²)	bit2(2 ¹)	bit1(2 ⁰)	not connect
8=I=gray	bit7(2 ⁶)	bit6(2 ⁵)	bit5(2 ⁴)	bit4(2 ³)	bit3(2 ²)	bit2(2 ¹)	bit1(2 ⁰)
7=H=blue	bit8(2 ⁷)	bit7(2 ⁶)	bit6(2 ⁵)	bit5(2 ⁴)	bit4(2 ³)	bit3(2 ²)	bit2(2 ¹)
6=G=yellow	bit9(2 ⁸)	bit8(2 ⁷)	bit7(2 ⁶)	bit6(2 ⁵)	bit5(2 ⁴)	bit4(2 ³)	bit3(2 ²)
5=F=green	bit10(2 ⁹)	bit9(2 ⁸)	bit8(2 ⁷)	bit7(2 ⁶)	bit6(2 ⁵)	bit5(2 ⁴)	bit4(2 ³)
4=E=white	bit11(2 ¹⁰)	bit10(2 ⁹)	bit9(2 ⁸)	bit8(2 ⁷)	bit7(2 ⁶)	bit6(2 ⁵)	bit5(2 ⁴)
3=D=brown	W (outside control direction: non-contact is CCW; connect to oV is CW)						
2=C=black	OV						
1=B=red	DC5V; DC8-30V						
0=A=shielding	GND						

Cable connection

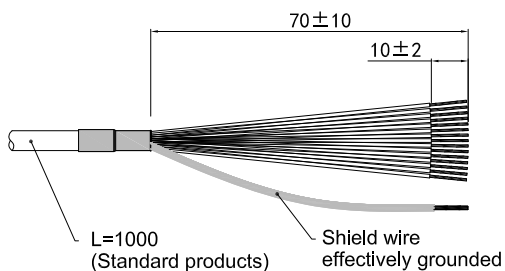

Cable with plug

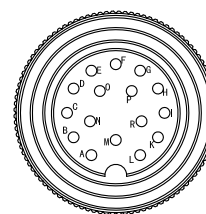

M16F-16K(plug)

9. Basic Dimensions

9.1 Dimensions

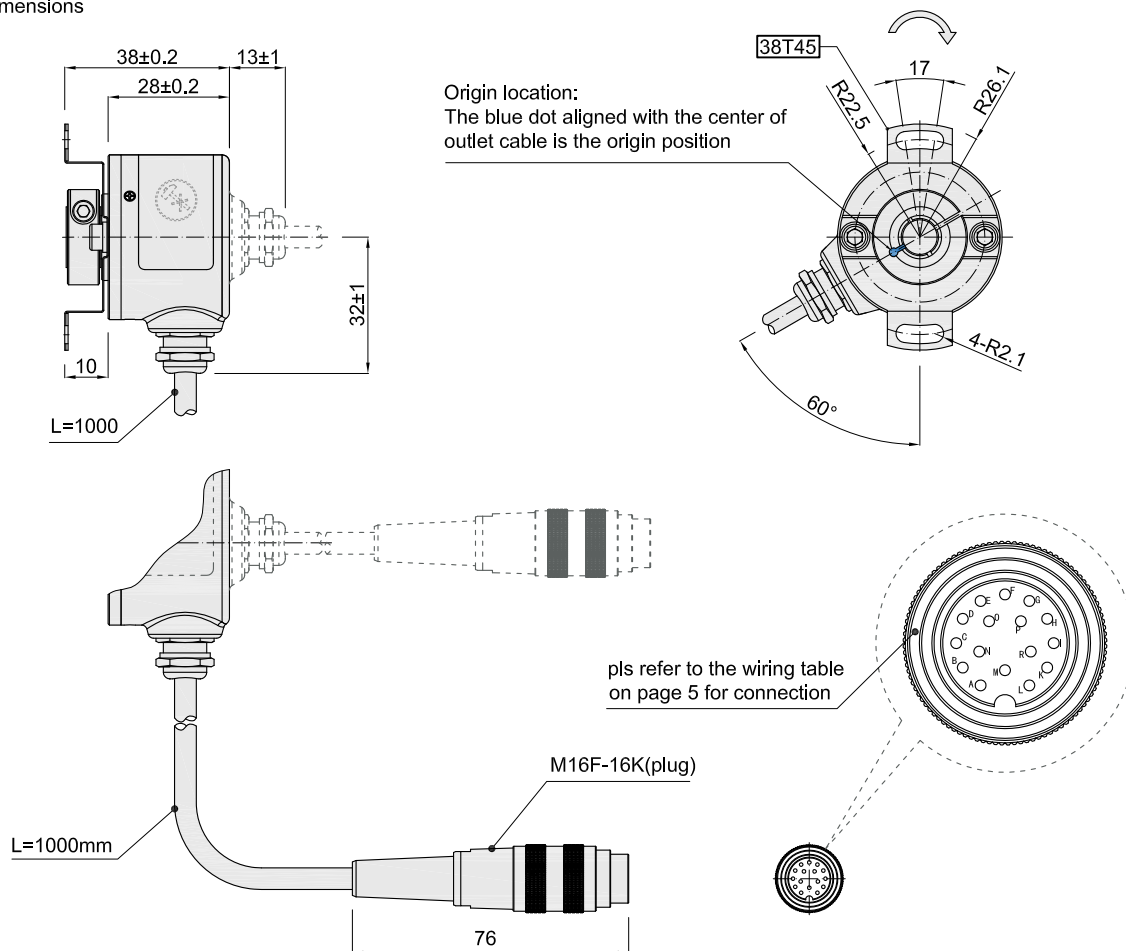

9.2 Assembling requirement

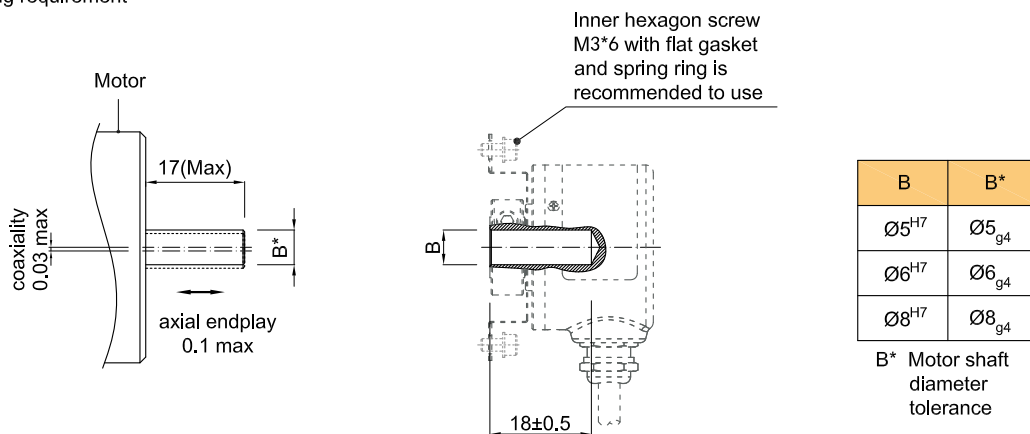

Unit: mm

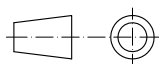

= Shaft rotation direction of the signal output

10. Caution

About vibration

Vibration act on encoder always cause wrong pulse, so we should pay attention to working place. More pulse per revolution, narrow groove spacing of grating, more effect to encoder by vibration, when rev is low or stop, vibration act on shaft or main body would cause grating vibrating, so encoder might make wrong pulse.